

MECHANICAL :

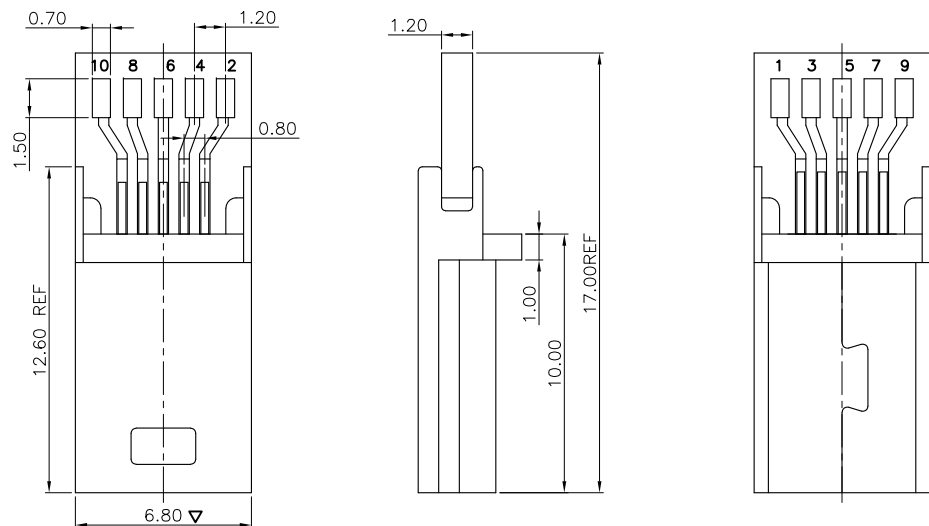

NOTE:

1. ELECTRICAL CHARACTERISTICS
 - 1-1. VOLTAGE RATING: 30V AC
 - 1-2. CURRENT RATING: 1.0A
 - 1-3. CONTACT RESISTANCE: 50 milliohms MAX.
 - 1-4. INSULATION RESISTANCE: 100 Megohms MIN.
 - 1-5. DIELECTRIC WITHSTANDING VOLTAGE: 500V AC FOR 1 MINUTE.
2. MECHANICAL CHARACTERISTICS
 - 2-1. RETENTION FORCE: MIN. 300gf/PIN
 - 2-2. DURIBILITY: 10000 CYCLES
3. SALT SPRAY: SEE TABLE
4. OPERATING TEMPERATURE: -40°C ~ 85°C
5. RoHS 2002/95/EC COMPLIANT.
6. CRITICAL DIMENSIONS : ▽

SHELL	1	SPCC, T=0.30	NICKEL 80-120u"
TERMINAL	4	C5191-EH, T=0.20	GOLD FLASH ON CONTACT AREA Matte. Sn 120uin Min. PLATED ON SOLDERING; 50uin NICKEL UNDER PLATING OVER ALL.
HOUSING	1	LCP 30%GF E130I	BLACK
DESCRIPTION	QTY	MATERIAL	PLATING & COLOR



Champyang International Ltd., Co

AO	RELEASED	Allen	2021-10-06
REV	DESCRIPTION.	APPD.	Date

FILE NO : ANU02 (Series)	TITLE 圖名	MINI USB 10P PLUG CLAMP WITH PCB		UNIT 單位	mm inch
TOLERANCE(公差): 0.000 mm ± 0.10mm 0.00 mm ± 0.25 mm 0.0 mm ± 0.30 mm	PART NO. 料號	ANU02-0110-F41-A		SCALE 比例	1:1
	DRAWN BY 製圖	Ray	DATE 日期	2021-10-06	REV. 版本
	CHECKED BY 審核	Allen	DATE 日期	2021-10-06	⊕