

RECOMMEND P.C.B LAYOUT (THICKNESS 0.8mm)  
(COMPONENT SIDE) TOLERANCE±0.03mm

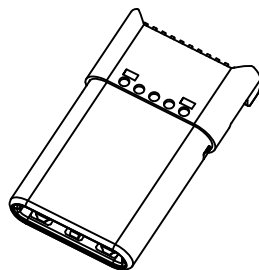
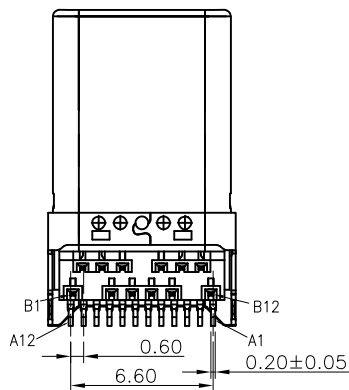
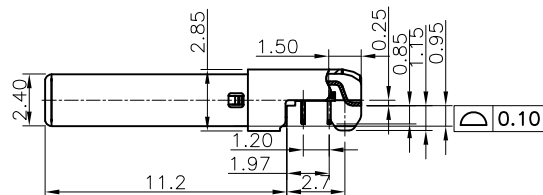
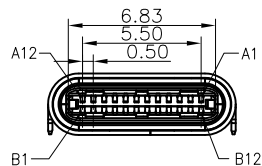

NOTE:

- 1.MATERIAL SPECIFICATION:
  - 1.HOUSING:LCP,UL94 V-0.
  - 2.TERMINAL: COPPER ALLOY
  - 3.MID PLATE: STAINLESS STEEL
  - 4.FRONT SHELL: STAINLESS STEEL
  - 5.EMI PLATE: STAINLESS STEEL
- 2.PLATING SPECIFICATION:
  - 2-1.TERMINAL:
    - Ni 50u" MIN. UNDER PLATED OVER ALL.
    - Au PLATED ON THE FUNCTIONAL AREA OF CONTACT.
    - (GOLD PLATING THICKNESS FOLLOW THE P/N)
    - PLATING SPECIFICATIONS OF THE SOLDER AREA FOLLOW THE P/N
  - 2-2.FRONT SHELL:
    - PLATING SPECIFICATIONS FOLLOW THE P/N
  - 2-3.MID PLATE&EMI PLATE:
    - CLEAR ONLY
- 3.MECHANICAL PERFORMANCE,
  - 3-1.INSERTION FORCE: 0.5~2.0kgf.
  - 3-2.REMOVAL FORCE: 0.8kgf~2.0kgf.
  - 3-3.DURABILITY: 10000 CYCLES.
- 4-1. VOLTAGE RATING:5 V DC/AC (RMS. max)  
CURRENT RATING:3 AMPS. FOR TOTAL VBUS/GND PINS;  
1.25AMPS FOR CC PIN,0.25 AMPS. FOR ALL OTHER CONTACT.  
VBUS & GND PINS AND OTHER PINS: 40mΩ/PIN MAX.  
SHIELD: 50mΩ/MAX.  
LLCR MAX. CHANGE OF ALL PINS: 10mΩ.  
4-3.INSULATION RESISTANCE: 100MΩ MIN  
4-4.DIELECTRIC WITHSTAND VOLTAGE,AC 100V FOR 1 MINUTE.
5. ENVIRONMENTAL PERFORMANCE:  
OPERATING TEMPERATURE: -25°C~+85°C.
- 6.IR REFLOW:  
THE PEAK TEMPERATURE ON THE BOARD SHALL

A1	GND	B12	GND
A2	TXp1	B11	RXp1
A3	TXn1	B10	RXn1
A4	VBUS	B9	VBUS
A5	CC1	B8	SBU2
A6	Dp1	B7	
A7	Dn1	B6	
A8	SBU1	B5	Vconn
A9	VBUS	B4	VBUS
A10	RXn2	B3	TXn2
A11	RXp2	B2	TXp2
A12	GND	B1	GND
PIN	SIGNAL NAME	PIN	SIGNAL NAME



Champyang International Ltd., Co

FILE NO : AUC12 ( Series)

TITLE  
圖名

TYPC CM 24P 前插後貼 沉板式  
板上高度1.67 CH=0.25

UNIT  
單位

mm  
inch

TOLERANCE(公差):  
0.000 mm ± 0.10 mm  
0.00 mm ± 0.25 mm  
0.0 mm ± 0.30 mm

PART NO.  
料號

AUC12-0124-F41-SD-B

SCALE  
比例

1:1

DRAWN BY  
製圖

Ray

DATE  
日期

2021-05-20

REV.  
版本

A.0

CHECKED BY  
審核

Allen

DATE  
日期

2021-05-20

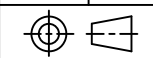

A0

RELEASED

Allen

2021-05-20

REV

DESCRIPTION.

APPD.

Date

A

B

C

D

Page: 1 of 2