

P.C.B LAYOUT

Specifications:

Electrical:

1. Current Rating: 1.5A/contact terminal
2. Voltage Rating: 30V DC
3. Contact Resistance: 30 milliohms MAX
4. Dielectric Withstanding Voltage: 500 V AC AT Sea Level
5. Insulation Resistance: 1000MEGA ohms MIN

Mechanical:

1. Connector Mate and Unmate Force:
Mate force: 35N (MAX)
Unmate force: 10N (MIN)
2. Terminal Retention: 10N (MIN)

Material:

1. Housing: High Temperature Thermoplastics,
UL 94V-0 LCP WHITE
2. Contact: Copper Alloy C2680/C5191
3. Shell: SPCC

Finish:

1. Contact: Plated Gold in Mating Area;
Tin On Solder Tails
2. Shell: Nickel Plating



Champyang International Ltd., Co

AO	RELEASED	Allen	2022-01-25
REV	DESCRIPTION.	APPD.	Date

FILE NO : AU209 (Series)		TITLE 圖名		USB2.0 AF SMT 捲邊鐵殼		UNIT 單位	mm inch
TOLERANCE(公差): 0.000 mm ± 0.10 mm 0.00 mm ± 0.25 mm 0.0 mm ± 0.30 mm		PART NO. 料號		AU209-0104-F43-D2		SCALE 比例	1:1
		DRAWN BY 製圖	Ray	DATE 日期	2022-01-25	REV. 版本	A0
		CHECKED BY 審核	Allen	DATE 日期	2022-01-25		

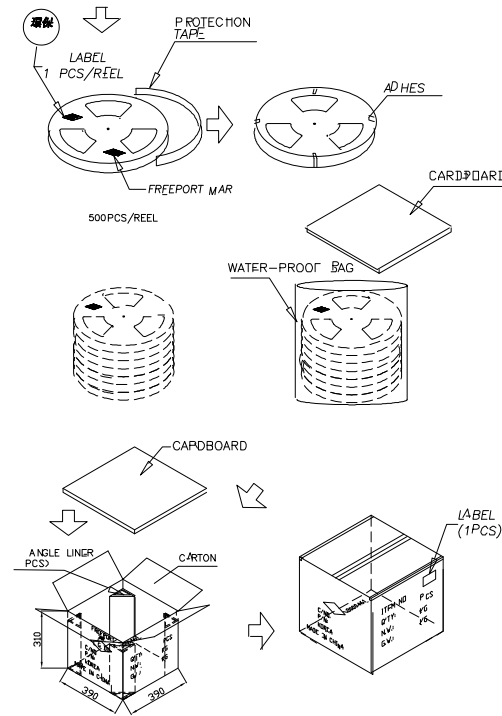
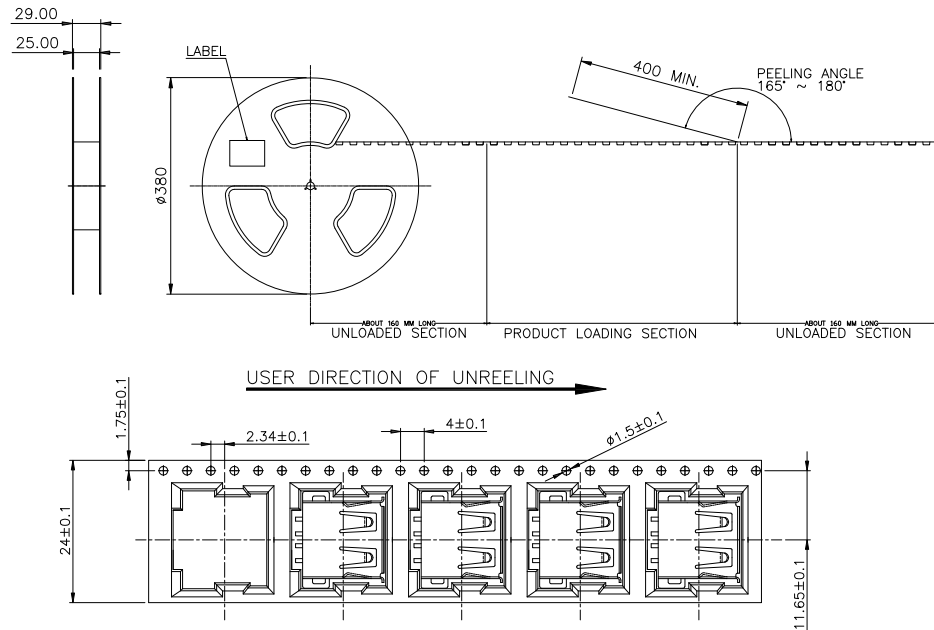

NOTE:

- MATERIAL:
 BOX: FIBREBOARD, CORRUGATED, DOUBLE WALL,
 TAPE: POLYSTYRENES, HEAT-RESISTANT TEMPERATURE: 120°C, BLACK COLOR.
 REEL: POLYSTYRENES, HEAT-RESISTANT TEMPERATURE: 70°C, BLUE COLOR.
 BAG: POLYETHYLENE, HEAT-RESISTANT TEMPERATURE: 100°C.
- PEELING STRENGTH: 0.1 ~ 1.3 N (10 ~ 130 GRAMS)
- PEELING SPEED: 300 mm/min.
- EACH BAG SHALL BE INCLUDED DESICCANT.

500	10	5000	-- KG	-- KG
PCS/REEL	REELS/CARTON	QUANTITY	GROSS WEIGHT	NET WEIGHT



Champyang International Ltd., Co

A0	RELEASED	Allen	2022-01-25
REV	DESCRIPTION.	APPD.	Date

FILE NO : AU209 (Series)		TITLE 圖名		USB2.0 AF SMT 捲邊鐵殼		UNIT 單位	mm inch
TOLERANCE(公差): 0.000 mm ± 0.10 mm 0.00 mm ± 0.25 mm 0.0 mm ± 0.30 mm		PART NO. 料號		AU209-0104-F43-D2		SCALE 比例	1:1
		DRAWN BY 製圖		Ray	DATE 日期	2022-01-25	REV. 版本
		CHECKED BY 審核		Allen	DATE 日期	2022-01-25	