

L K J I H

3

2

1

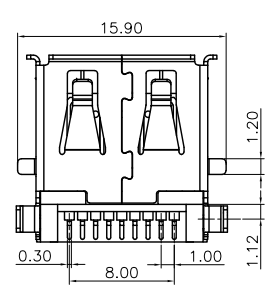
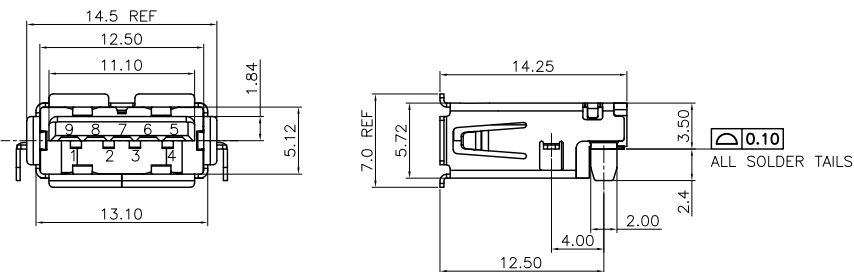
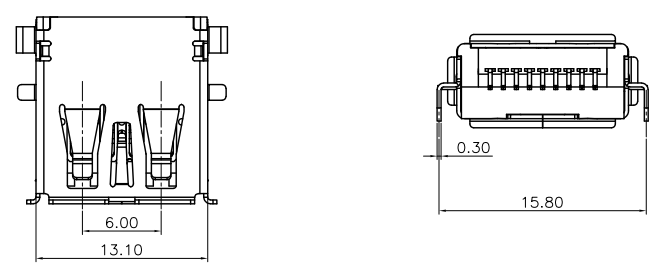

Pin NUMBER	SIGNAL NAME
1	VBUS
2	D-
3	D+
4	GND
5	StdA_SSRX-
6	StdA_SSRX+
7	GND_DRAIN
8	StdA_SSTX-
9	StdA_SSTX+
Shell	Shield

NOTE:
 1.MATERIAL:
 1.1 INSULATOR:LCP UL 94V-0
 1.2 CONTACT:BRONZE(T=0.20mm)
 1.3 SHELL:SUS201(T=0.30mm)
 2.ELECTRICAL CHARACTERISTICS:
 2.1 CONTACTRESISTANCE:30mΩ MAXIMUM
 2.2 CONTACT CURRENT RATING:1.5A
 2.3 DIELECTRIC WITHSTANDING VOLTAGE:500 V
 R.M.S.
 2.4 INSULATION RESISTANCE 1000 MEGOHMS MIN
 2.5 OPERATING TEMPERATURE:-40°C ~ 85°C
 3 MECHANICAL CHARACTERISTICS:
 3.1 MATING FORCE:3.57kg MAX
 3.2 UNMATED FORCE:1.02kg MIN
 3.3 DURABILITY:MANDATORY:5,000 CYCLES
 4.PLATING
 4.1 TERMINAL:
 50u" MIN NICKEL ALL OVER
 100u"MIN Tin ON SOLDER AREA
 (1~30)u"Au ON CONTACT AREA
 4.2 SHELL:100u"MIN.NICEL ALL OVER

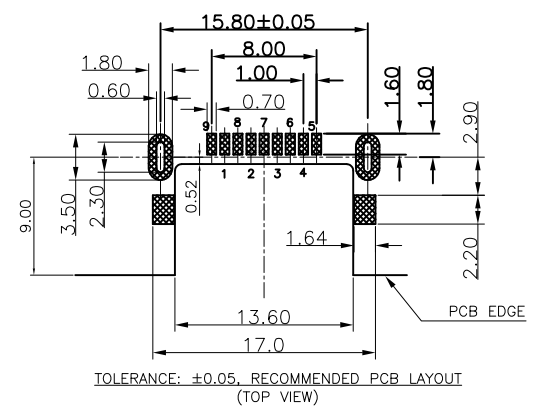

Champyang International Ltd., Co

A0	RELEASED	Allen	2021-08-02
REV	DESCRIPTION.	APPD.	Date

FILE NO : AU303 (Series)		TITLE 圖名		USB3.0 AF 沉板3.5mm SMT 有掩邊 方腳DIP		UNIT 單位	mm inch
TOLERANCE(公差): 0.000 mm ± 0.075 mm 0.00 mm ± 0.15 mm 0.0 mm ± 0.25 mm		PART NO. 料號		AU303-0109-F42-S1-A-RP		SCALE 比例	1:1
		DRAWN BY 製圖		Ray	DATE 日期	2021-08-02	REV. 版本
		CHECKED BY 審核		Allen	DATE 日期	2021-08-02	A0