

MECHANICAL:

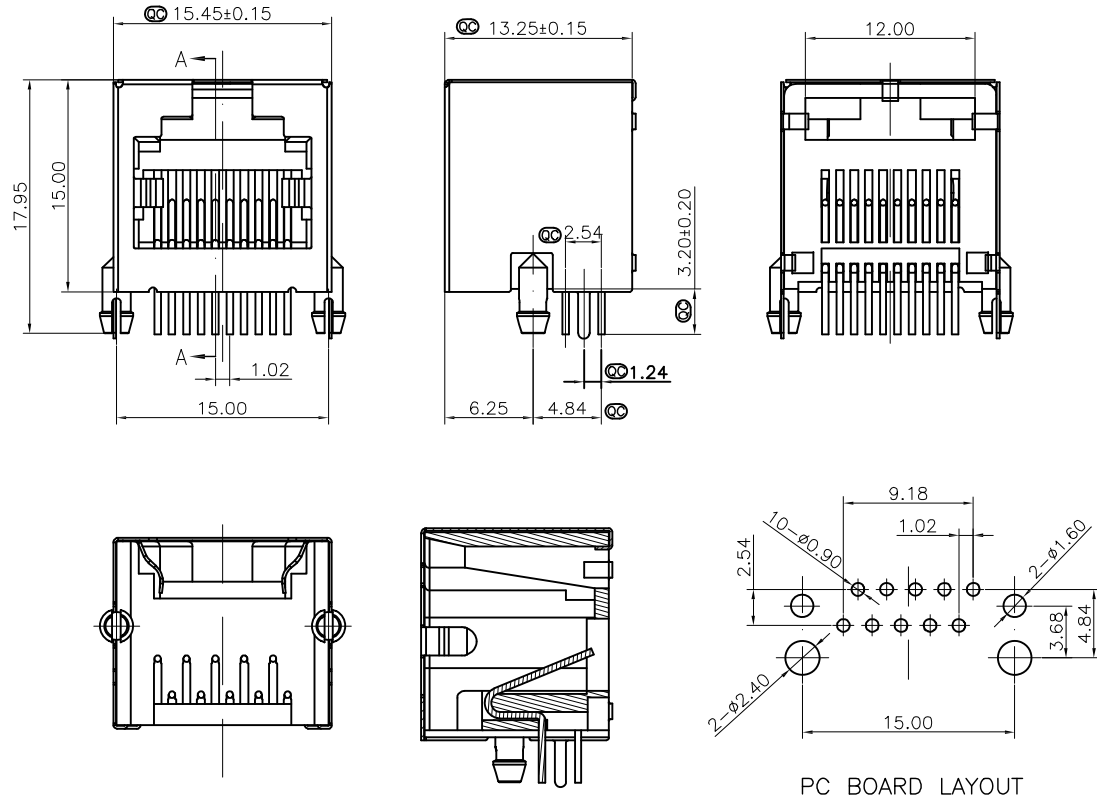

NOTES:

ELECTRICAL:

- VOLTAGE RATING : 125 VAC RMS.
- CURRENT RATING : 1.5 AMP.
- CONTACT RESISTANCE : 50 MILLIOHMS MAX.
- INSULATION RESISTANCE: 500 MEGOHMS MIN @ 500 VDC.
- DIELECTRIC STRENGTH : 500 VAC RMS 50Hz, 1MIN.

MECHANICAL:

- HOUSING MATERIAL : PBT+20%GF (UL94V-0).
- CONTACT MATERIAL : PHOSPHOR BRONZE ø0.46mm
- PLATING : GOLD PLATING OVER NICKEL.
- SHIELD: COPPER ALLOY(OR STEEL ALLOY) 0.20mm THICKNESS
- OPERATING LIFE : 750 CYCLES MIN.
- PCB RETENTION PRE-SOLDER : 1 LB MIN.
- PCB RETENTION POST-SOLDER: 10 LBS MIN.

ENVIRONMENTAL:

- STORAGE : -40°C TO +85°C.
- OPERATION: 0°C TO +70°C.
- WAVE SOLDERING TEMPERATURE: 230°C TO 250°C(5-10 SECONDS).
- ROHS COMPLIANT

FCC PART 68, SUBPART F.

MATES WITH MODULAR PLUG CONFORMING TO



Champyang International Ltd., Co

A0	RELEASED	Allen	2019-12-25
REV	DESCRIPTION.	APPD.	Date

FILE NO : ARJ03(Series)		TITLE 圖名		RJ45 10P10C SIDE ENTRY WITH SHIELDED		UNIT 單位	mm inch
TOLERANCE(公差): 0.000 mm ± 0.10 mm 0.00 mm ± 0.25 mm 0.0 mm ± 0.38 mm		PART NO. 料號		ARJ03-01010-F21-S0		SCALE 比例	1:1
		DRAWN BY 製圖		Ben	DATE 日期	2019-12-25	REV. 版本
		CHECKED BY 審核		Allen	DATE 日期	2019-12-25	