

MECHANICAL :

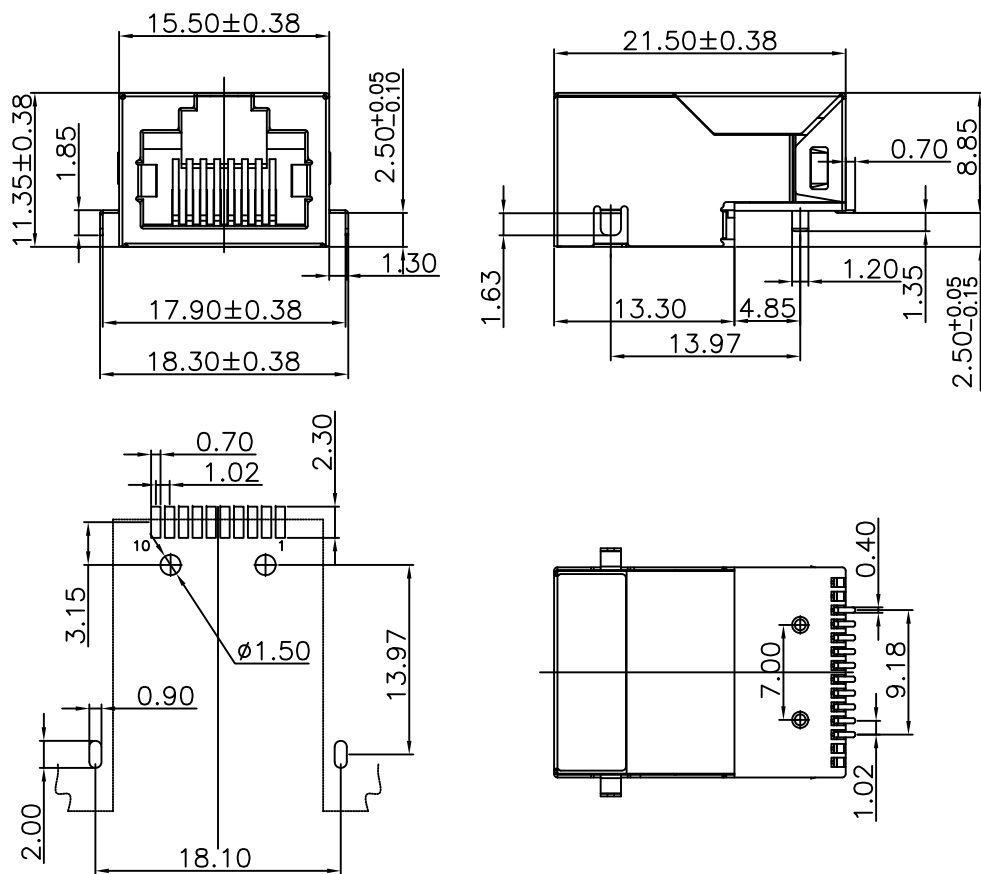

Recommended P.C.Board  
Layout  
(Tolerance:±0.05)

Metal Shell :Copper Alloy, Finish: 30u" Nickel  
 Housing :Thermoplastic,LCP,UL 94V-0,Black  
 Insert :Thermoplastic,LCP,UL 94V-0,Black  
 Contact Terminal/phosphor Bronze  
 6u" Gold on Contact Area, 100u" Tin on Solder,  
 Both over 50u" Nickel Under-Plated  
 Coil Base :Phenolic,LCP,UL 94V-0,Black  
 Terminal/Copper Alloy T=0.35mm Thickness

Meets or exceeds IEEE 802.3 standard for 10/100/1000 Base-TX  
 350uH minimum OCL with 8mA Bias current  
 Available with or without LEDs  
 Minimum 1500Vrms isolation per IEEE802.3 requirement  
 Operating temperature 0°C to +70°C  
 Storage temperature -40°C to +85°C



Champyang International Ltd., Co

REV	DESCRIPTION.	APPD.	Date
A0	RELEASED	Allen	2019-06-10

FILE NO : ARJ15 ( Series)		TITLE 圖名		RJ45 Connector With Transformer 1000Base Tab-up 1x1 Port		UNIT 單位	mm inch
TOLERANCE(公差): 0.000 mm ± 0.075 mm 0.00 mm ± 0.15 mm 0.0 mm ± 0.25 mm		PART NO. 料號		ARJ15-010810-341-SOT2-S-A		SCALE 比例	1:1
		DRAWN BY 製圖		Ben	DATE 日期	2019-06-10	REV. 版本
		CHECKED BY 審核		Allen	DATE 日期	2019-06-10	A.0

ELECTRICAL SPECIFICATIONS@25°C UNLESS OTHERWISE NOTED:

1. Turn Ratio(+/-2%):1CT:1CT
2. Inductance OCL:  
350uH Min @100KHz 0.1V DC BIAS 8mA
3. Insertion Loss:  
-1.0dB Max @1.0-100MHz
4. Return Loss:  
-20dB Min @1-30MHz  
-16dB Min @30-60MHz  
-12dB Min @60-80MHz
5. Cross talk:  
-40dB Min @1-30MHz  
-35dB Min @30-80MHz
6. Common Mode Rejection:  
-35dB Min @1-100MHz  
-20dB Min @50-150MHz
7. HIPOT TEST:1500Vrms 1mA.Max

## SCHEMATICS :

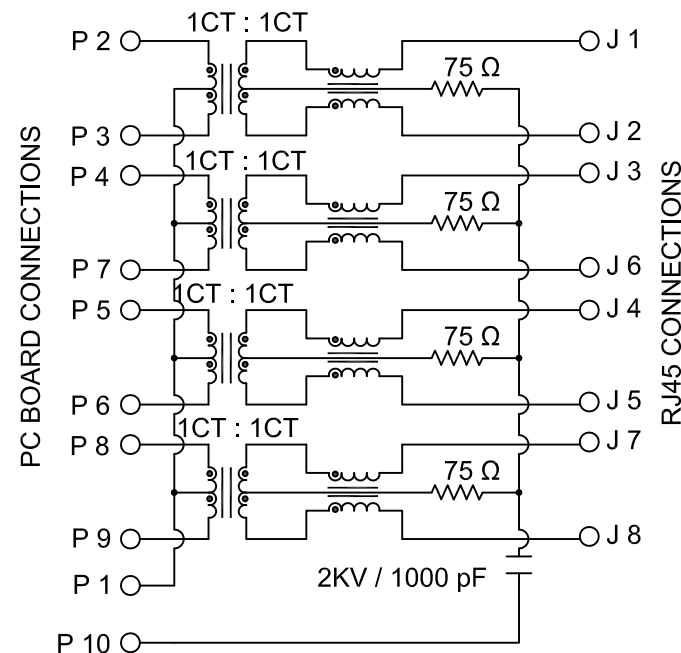

Champyang International Ltd., Co

A0	RELEASED	Allen	2019-06-10
REV	DESCRIPTION.	APPD.	Date

FILE NO : ARJ15( Series)		TITLE 圖名		RJ45 Connector With Transformer 1000Base Tab-up 1x1 Port		UNIT 單位	mm inch
TOLERANCE(公差): 0.000 mm ± 0.075 mm 0.00 mm ± 0.15 mm 0.0 mm ± 0.25 mm		PART NO. 料號		ARJ15-010810-341-S0T2-S-A		SCALE 比例	1:1
DRAWN BY 製圖		Ben		DATE 日期		2019-06-10	
CHECKED BY 審核		Allen		DATE 日期		2019-06-10	