

NOTES:

- 1. MATERIAL:
  - SHELL: BRASS t=0.3 mm
  - HOUSING: THERMOPLASTIC, GLASS FIBER FILLED  
UL 94V-0 RATED
  - CONTACT: PHOSPHOR BRONZE t=0.25 mm
- 2. PLATING:
  - SHELL: 1= 100u" TIN OVER 50u" Cu  
2= 50u" NICKEL OVER 50u" Cu  
3= 100u" TIN OVER 50u" Cu
  - CONTACT: UNDER PLATED 50u" NICKEL, OVER ALL  
120u" TIN IN SOLDERING AREA,  
SELECTIVE GOLD PLATED CONTACT AREA.

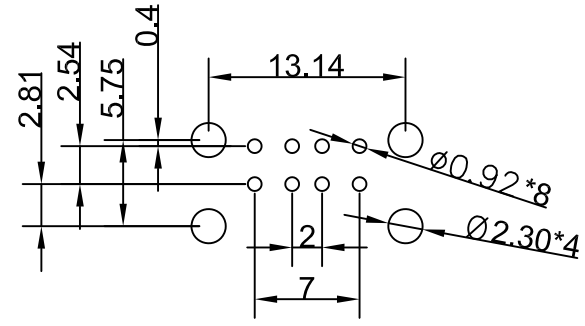

PC BOARD FOOTPRINT

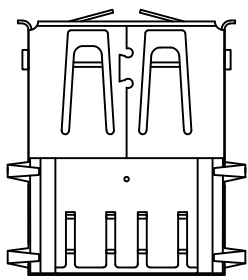
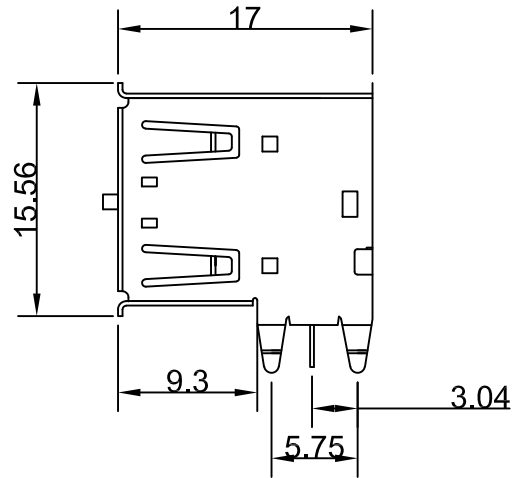
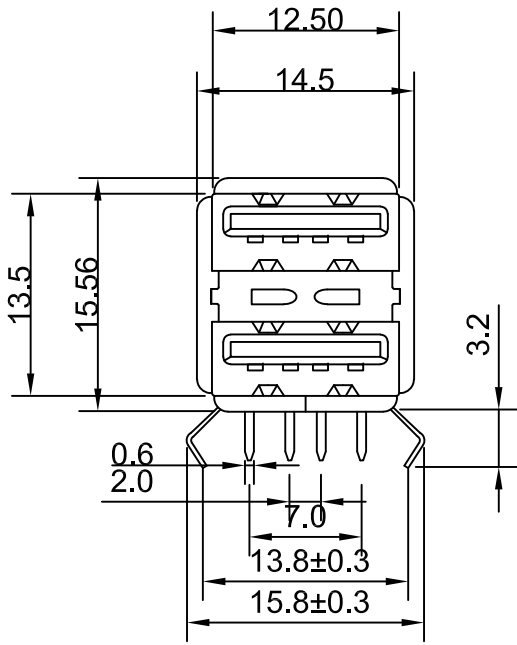

Champyang International Ltd., Co

NO	REV	DESCRIPTION.	APPD.	Date
		RELEASED	Allen	2019-11-08

FILE NO : AU201 ( Series)		TITLE 圖名		USB Type A DOUBLE PORT DIP 90°		UNIT 單位	mm inch
TOLERANCE(公差): 0.000 mm ± 0.05 mm 0.00 mm ± 0.10 mm 0.0 mm ± 0.20 mm		PART NO. 料號		AU201-0204-F21-D-B		SCALE 比例	1:1
		DRAWN BY 製圖		Ben	DATE 日期	2019-11-08	REV. 版本
		CHECKED BY 審核		Allen	DATE 日期	2019-11-08	