

MECHANICAL:

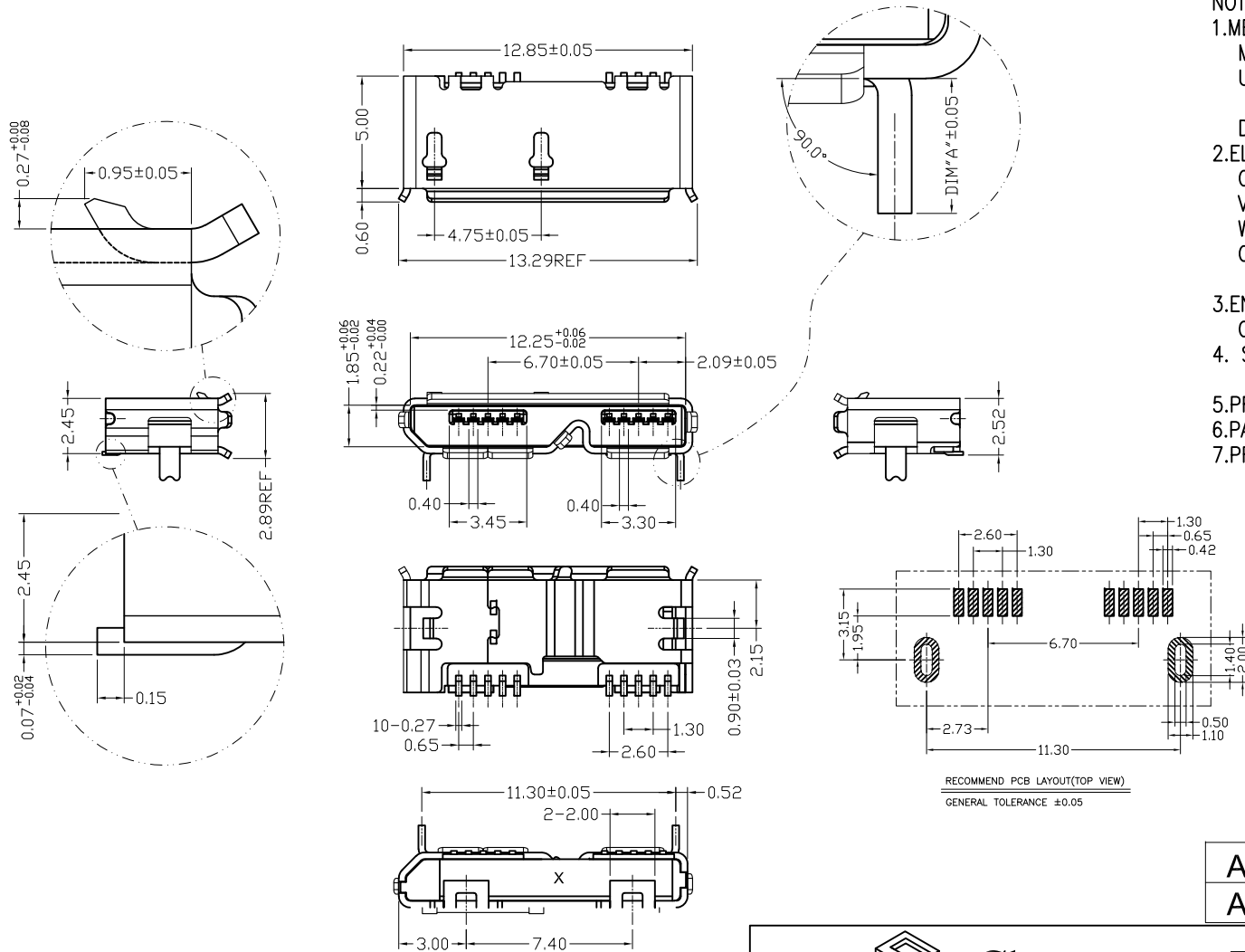

- NOTES:
- MECHANICAL:
 - MATING FORCE: 35N MAX.
 - UNMATING FORCE: 10N MIN,INITIAL.
 - 8~20N AFTER 10000 CYCLES.
 - DURABILITY: 5000 CYCLES MIN.
 - ELECTRICAL:
 - CURRENT: 1.0A
 - VOLTAGE: 30V MAX
 - WITHSTANDING VOLTAGE: 100V AC
 - CONTACT RESISTANCE: 30 mΩ MAX INITIAL;
 - 40 mΩ MAX AFTER 10000 CYCLES
 - ENVIRONMENTAL
 - OPERATING TEMPERATURE RANGE -30°C ~ +80°C
 - SALT SPRAY : 24 H AT 35%DC WITH 5%-SALT-SOLUTION CONCENTRATION.
 - PRODUCT SPEC:SP-MICRO USB-001
 - PACKAGE SPEC:DWG-PK MUB-OXX
 - PRODUCT MEET FOR ROHS STANDARD

The following part fittings of a machine		
PART NAME	Q'TY	Material
Housing	1	LCP 130i Black
Terminal	10	C5191R-H,T=0.15mm; G/F
shell	1	SUS304-1/2H,T=0.30mm

AU307-0110-F41-S21-1	DIMA=0.85
AU307-0110-F41-S21-2	DIMA=1.20

 Champyang International Ltd., Co

A1	RELEASED	Allen	2020-04-24
REV	DESCRIPTION.	APPD.	Date

FILE NO : AU307(Series)		TITLE 圖名		MICRO USB 3.0雙腳 捲邊母座		UNIT 單位	mm inch
TOLERANCE(公差): 0.000 mm ± 0.075 mm 0.00 mm ± 0.15 mm 0.0 mm ± 0.25 mm		PART NO. 料號		AU307-0110-F41-S21-2		SCALE 比例	1:1
DRAWN BY 製圖		Ben	DATE 日期	2020-04-24	REV. 版本	A1	
CHECKED BY 審核		Allen	DATE 日期	2020-04-24			